

# DATA SHEET

## PRESSURE REGULATORS



**Stainless Steel**      **7366**  
**Model:**



### FEATURES

- Maintains full pressure while running in idle for quick return to system pressure.
- Offers pump protection against pressure fluctuations and system changes.
- Minimum pressure fluctuations with the alternating use of multiple guns and nozzles.
- Top adjusting handle and locking nut to secure exact pressure setting.
- No external moving parts. Stainless Steel and FPM internal parts for temperature and liquid compatibility.

### SPECIFICATIONS

	U.S.	Metric
Flow Range	1 - 12 gpm	3.78 - 45.4 lpm
Pressure Range	3000 - 6000 psi	207 - 414 bar
Maximum Temperature	180° F	82° C
Inlet Port	1/2" NPT(F)	1/2" NPT(F)
By-Pass Port	3/4" NPT(F)	3/4" NPT(F)
Weight	6.2 lbs.	2.8 kg
Dimensions	9.1 x 3.43 x 2.38"	231 x 87 x 60.45 mm

## Read all CAUTIONS and WARNINGS before commencing service or operation of any high-pressure system

### SELECTION

This pressure regulator is designed for systems with single or multiple pumps, solenoid (gate) valves, nozzles, standard or "weep" guns.

**Note:** For multiple pump systems, it is best to use a pressure regulator not a pressure sensitive regulating unloader.

This regulator should meet both the desired system flow (combined nozzle flow rate requirement) and the desired system pressure.

**Note:** Operation below the minimum flow of the regulator causes the regulator to cycle or chatter. Operation above the maximum flows of the regulator causes premature regulator wear, regulator cycling and prevents attaining desired system pressure.

### INSTALLATION

This regulator operates properly when mounted in any direction; however, it is preferred to keep the plumbing to a minimum and the adjusting cap easily accessible. The best mounting location is directly on the pump discharge manifold head or in discharge line using a "T" fitting. Flexible, high pressure hose (minimum single wire braid) should be at least the size of the regulator ports when plumbing to and from the regulator.

The inlet connection is located on the side and is a 1/2" NPT(F) sized port. Plumb into this port for the discharge flow from the pump.

The by-pass connection is located on the bottom and is a 3/4" NPT(F) sized port. By-pass fluid is directed out of this port and can be routed to a reservoir or to a drain.

### OPERATION

This pressure regulator maintains established system pressure in the discharge line and at the pump head when the trigger gun is closed, solenoid (gate) valve is closed or the nozzles are clogged, thus by-passing all unrequired flow. Squeezing the trigger gun or opening the solenoid (gate) valve allows for a quick return to established system pressure.

### PRESSURE ADJUSTMENT

1. Setting and adjusting the regulator pressure must be done with the system "on".
2. Start the system with regulator backed off to the lowest pressure setting (counterclockwise direction).
3. Squeeze the trigger and read the pressure on the gauge at the pump.  
**Note:** Do not read the pressure at the gun or nozzle.
4. If more pressure is desired, release the trigger, turn adjusting handle one quarter turn in clockwise direction.
5. Squeeze the trigger and read the pressure.
6. Repeat this process until desired system pressure is attained.
7. Once the desired system pressure is reached, stop turning the adjusting handle and thread lock nut down towards upper body of regulator to lock in place.

**Note:** A minimum by-pass flow of 10% of the regulator rated flow is required for proper regulator performance. If the entire output is directed through the nozzles (zero by-pass) the "cushioning" feature of the by-pass liquid is eliminated and the regulator can malfunction or wear prematurely.

8. If desired system pressure cannot be reached, review TROUBLESHOOTING chart.
9. When servicing existing systems, back off lock nut.
10. Follow adjustment procedures as stated above for new regulators.

**Note:** Do not adjust regulators pressure setting to compensate for a worn nozzle. Check the nozzle as part of the regular maintenance and replace if worn.

**Note:** A secondary pressure relief device (i.e., pop-off valve) should be used along with this pressure regulator. Final adjustment for the relief valve should relieve at 200 psi above the system operating pressure.

### TYPICAL REGULATOR INSTALLATION

1. Pressure Gauge
2. Relief Valve (shown as a secondary relief valve)
3. Pulsation Dampener
4. Pressure Regulator
5. Triplex Plunger Pump

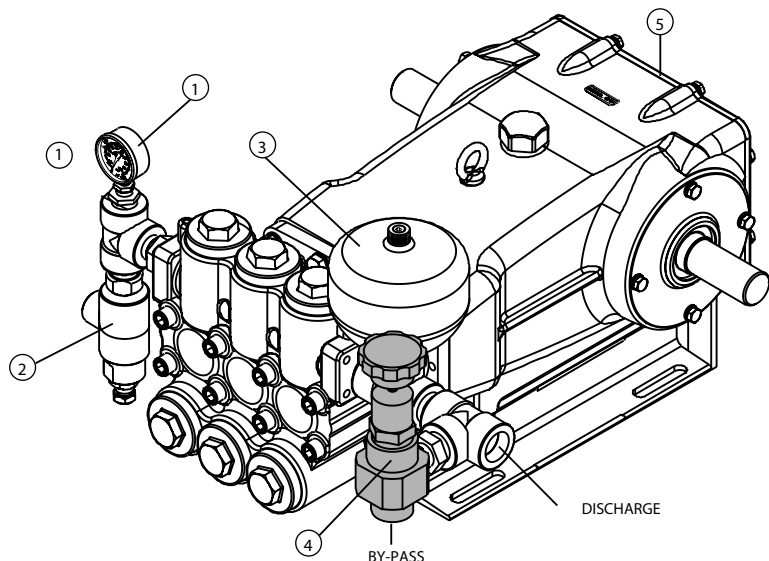

## Read all CAUTIONS and WARNINGS before commencing service or operation of any high-pressure system

### SERVICING

#### Disassembly

1. Disconnect by-pass and inlet plumbing from regulator.
2. Remove regulator from pump.
3. Secure lower body of regulator in a vise with adjusting handle facing up.
4. Remove adjusting handle and screw from upper body.
5. Remove upper body by unthreading from lower body.
6. Remove first spring retainer, spring and second spring retainer from lower body.
7. Remove lower body from vise.
8. Place lower body upside down on a flat surface with by-pass port facing up. Grasp lower body and gently tap against flat surface. Piston guide and ball will fall out.
9. Grasp lower body and gently tap against flat surface to remove piston insert, piston and spring.
10. Separate piston and spring from piston insert.
11. Place lower body with by-pass port facing up on flat surface. Using a tool with the same diameter as that of the seat, drive out seat.

**Notice:** Exercise extreme caution to avoid contact and damage to the inside diameter of the piston insert, lower body sealing areas and seat. Exercise extreme caution to avoid contact and damage to the outside diameter of the piston insert, piston and seat.

**Note:** With the regulator completely disassembled, inspect sealing area where the seat and piston insert makes contact within the lower body of the regulator for grooves, pitting and wear. If damage is found, stop the repair and replace with new lower body or complete new regulator. If not, proceed with reassembly.

#### Reassembly

1. Place lower body with by-pass port facing down on a flat surface.
2. Lubricate outside diameter of seat. Press seat into lower body with small diameter surface facing down. Ensure seat lip rests squarely on lower body surface.
3. Lubricate and install backup-ring and o-rings onto outer diameter of piston insert and into inside diameter of piston insert. Press piston insert with small diameter down into lower body.
4. Install ball and then spring onto seat.
5. Lubricate and install o-rings onto outside diameter of piston.
6. Place piston over spring.
7. Place piston guide on top of piston. Insert ball into center hole of piston guide.
8. Place first spring retainer with stepped side facing up onto piston guide.
9. Install spring onto first spring retainer and then place second spring retainer on spring with stepped side facing down.
10. To install the upper body onto the lower body, use the hole in the upper body to fit screwdriver through to support the stacked internal parts. Thread upper body onto lower body while holding parts in place with screwdriver. Remove screwdriver.
11. Thread in adjusting handle with screw through hole in upper body.
12. Re-install regulator onto pump.
13. Reconnect by-pass and inlet plumbing to regulator.
14. Proceed to PRESSURE ADJUSTMENT.

### TROUBLE SHOOTING

Cycling/Chattering	<ul style="list-style-type: none"> <li>• Too little flow for valve specifications.</li> <li>• Air in system, poor connections.</li> <li>• Inlet seals in pump worn.</li> <li>• O-ring in gun worn.</li> </ul>
System will not build up to pressure	<ul style="list-style-type: none"> <li>• Nozzle worn.</li> <li>• Improper nozzle size for system specs.</li> <li>• Foreign material trapped in seat.</li> </ul>
Pressure drop	<ul style="list-style-type: none"> <li>• Nozzles worn.</li> <li>• Piston and seat in regulator worn.</li> <li>• Air in system, poor connections.</li> <li>• Insufficient flow to pump.</li> <li>• Filter clogged. Check and clean regularly.</li> </ul>
Pressure spikes while in by-pass	<ul style="list-style-type: none"> <li>• Minimum by-pass of 10% not present.</li> <li>• Excessive pressure adjustment made for worn nozzle REPLACE NOZZLE. Reset system pressure.</li> </ul>
Leakage from regulator vent hole	<ul style="list-style-type: none"> <li>• O-ring around piston worn or piston retainer scored. Service with o-ring kit.</li> </ul>

### PRESSURE READING

Approximate Pressure Reading at Gauge	Gauge Between Pump/Regulator	Gauge Between Regulator/Gun-Nozzle-Valve
System in operation (gun open)	System Pressure	System Pressure
System in by-pass (all guns, valves closed)	200 - 300 psi above system pressure	200 - 300 psi above system pressure

## EXPLODED VIEW

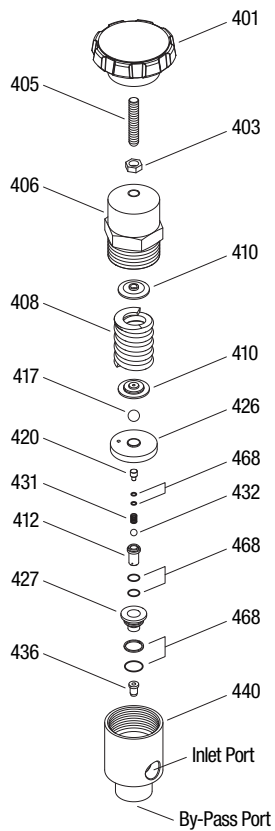

## PARTS LIST

ITEM	P/N	MATL	DESCRIPTION	QTY
401	30948	NY R	Handle, Adjusting	1
403	30933	S	Nut, Lock	1
405	30932	S	Adjuster, Pressure	1
406	—	STNP	Body, Upper	1
408	30935	STL R	Spring	1
410	34289	BB R	Retainer, Spring	2
412	76472	SS	Piston	1
417	34031	SSSS	Ball, Retainer	1
420	76473	SS	Spacer, Ball	1
426	34033	BB R	Guide, Piston	1
427	76474	SS	Insert, Piston	1
431	34000	S	Spring, Piston	1
432	34001	SSSS	Ball, Seat	1
436	32103	SS	Seat	1
440	—	SS	Body, Lower Hex	1
468	32141	FPM R	Kit, O-Ring	1

Italics are optional items. R Components comply with RoHS Directive.  
 Material Codes (Not Part of Part Number): BB=Brass FPM=Fluorocarbon  
 NY=Nylon STNP=Steel/Nickel Plated S=304SS SS=316SS SSSS=440SS  
 STL=Steel

### ⚠ CAUTIONS AND WARNINGS

All High Pressure Systems require a primary pressure regulating device (i.e. regulator, unloader) and a secondary pressure relief device (i.e. pop-off valve, relief valve). Failure to install such relief devices could result in personal injury or damage to pump or property. Cat Pumps does not assume any liability or responsibility for the operation of a customer's high pressure system.

Read all CAUTIONS and WARNINGS before commencing service or operation of any high pressure system. The CAUTIONS and WARNINGS are included in each service manual and with each Accessory Data sheet. CAUTIONS and WARNINGS can also be viewed online at [www.catpumps.com/cautions-warnings](http://www.catpumps.com/cautions-warnings) or can be requested directly from Cat Pumps.

### WARRANTY

View the Limited Warranty on-line at [www.catpumps.com/warranty](http://www.catpumps.com/warranty).



#### CAT PUMPS

1681 - 94TH LANE N.E. MINNEAPOLIS, MN 55449-4324  
 PHONE (763) 780-5440 — FAX (763) 780-2958  
 e-mail: [techsupport@catpumps.com](mailto:techsupport@catpumps.com)  
[www.catpumps.com](http://www.catpumps.com)